

# GATE 149

## BRONZE

125 lb. SWP-200 lb. WOG† • General Service  
 Solid Wedge Disc • Rising Stem  
 Threaded Bonnet • Gland Packed • Sweat Ends

4" size has split wedge and bolted bonnet. It is not covered in MSS SP-80.

### SPECIFICATIONS

149	Conforms to: MSS SP-80. Type 2, Class 125, Soldered Ends.
-----	---

### MATERIAL LIST

NO.	PART	MATERIAL	SPECIFICATION
1	Body	Bronze	ASTM B 62
2	Bonnet	Bronze	ASTM B 62
3	Wedge	Bronze	ASTM B 62
4	Stem	Bronze	ASTM B 62
5	Stuff Nut	Brass	ASTM B283 C37700
6 <sup>1</sup>	Gland	Brass	ASTM B124 C37700
7	Wheel Nut	Brass	Commercial
8	Handwheel	Mall. Iron	Commercial
9	Packing	Graphite	Commercial
10	Name Plate	Sh. Alum.	Commercial

<sup>1</sup> Not used on 1/2" and smaller.

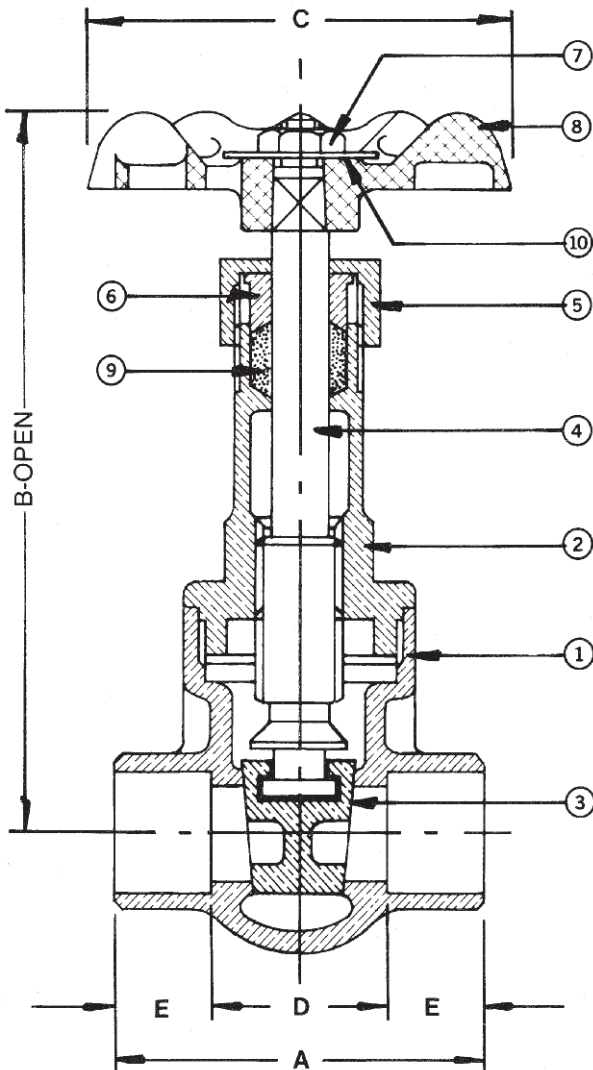

### DIMENSIONS - INCHES / MILLIMETERS

Units	Size	A	B	C	D	E	C <sub>v</sub>
Inches	3/8	1.63	4.31	2.00	0.88	0.38	5.6
mm	9.5	41.3	109.6	50.8	22.3	9.5	
Inches	1/2	1.88	4.31	2.00	0.88	0.50	10.7
mm	12.7	47.6	109.6	50.8	22.3	12.7	
Inches	3/4	2.50	6.25	2.50	1.00	0.75	17.6
mm	19.1	63.5	158.8	63.5	25.4	19.1	
Inches	1	3.00	7.00	2.75	1.19	0.91	32.0
mm	25.4	76.2	177.8	69.9	30.2	23.0	
Inches	1 1/4	3.25	8.63	3.13	1.31	0.97	54.0
mm	31.8	82.6	219.1	79.4	33.4	24.6	
Inches	1 1/2	3.63	9.50	3.50	1.44	1.09	97.0
mm	38.1	92.1	241.3	88.9	36.5	27.8	
Inches	2	4.31	11.50	3.75	1.63	1.34	135.0
mm	50.8	109.6	292.1	95.3	41.3	34.1	
Inches	2 1/2	4.81	14.31	4.75	1.88	1.47	230.0
mm	63.5	122.3	363.6	120.7	47.6	37.3	
Inches	3	5.44	16.38	5.25	2.13	1.66	337.0
mm	76.2	138.1	415.9	133.4	54.0	42.1	
Inches	4	7.25	15.50	5.25	2.16	2.94	536.0
mm	101.6	184.2	393.7	133.4	54.8	74.6	

† Non-Shock

Rev 5

**INNOVATION** IN EVERY VALVE



**MILWAUKEE VALVE**

www.milwaukeevalve.com

The information presented on this sheet is correct at the time of publication. Milwaukee Valve reserves the right to change design, and/or material specifications without notice. For the Installation, Operation and Maintenance Manual (IOM) see the engineering section on our website. For the most current information access [www.milwaukeevalve.com](http://www.milwaukeevalve.com)